

CENTRIFUGAL FANS

HIGH HEAD

Double inlet

ebmpapst

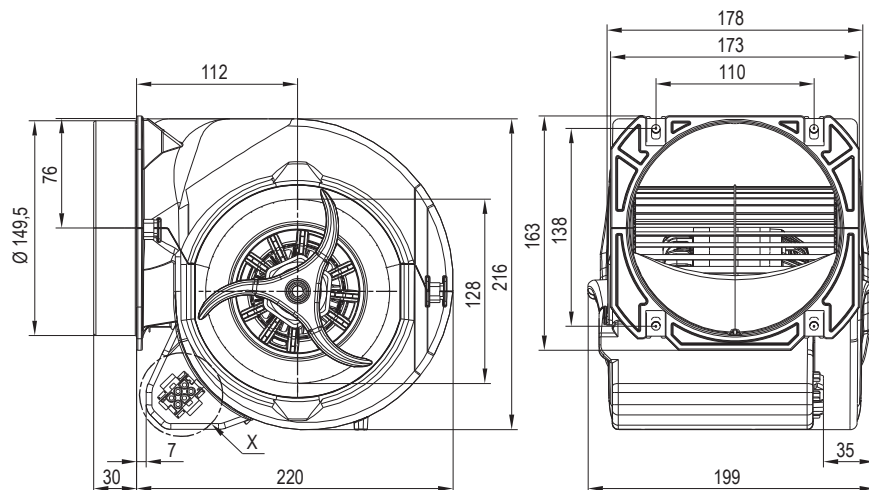

These fans come complete with connecting cable.

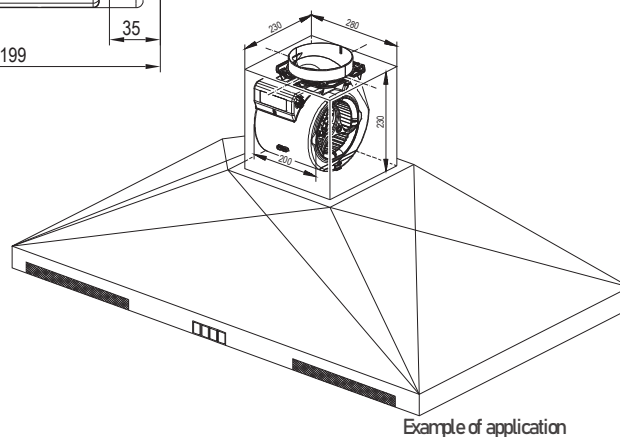

Example of application

MODEL	VAC	HZ	m ³ /h	rpm	W	A	μF	dB(A)	°C	kg	CODE
D2E146-HR93-A2	230	50	630	1100	145	0.66	4	51	-20..+50	3.0	0412010
D2E146-HT59-02	230	50	1060	1500	320	1.55	8	66	-20..+50	3.6	0412011-ERP

GENERAL CHARACTERISTICS:

Centrifugal fan with double inlet, single-phase, with 149 mm expulsion outlet, suitable for application in which high heads and low noise levels are required.

USES:

- Industrial cooker hoods
- Heat recovery units
- Specific machinery for the cosmetics industry
- Spare ventilation unit for extraction boxes
- Extraction of fumes at max 50°C with pipes for high heads