

SMOKE EXTRACTORS

R2E150-AN91-22

Specifically for solid fuels

ebmpapst

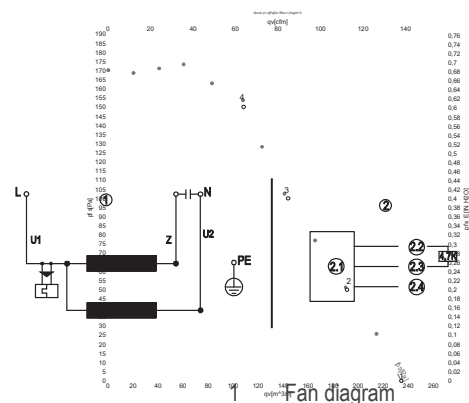
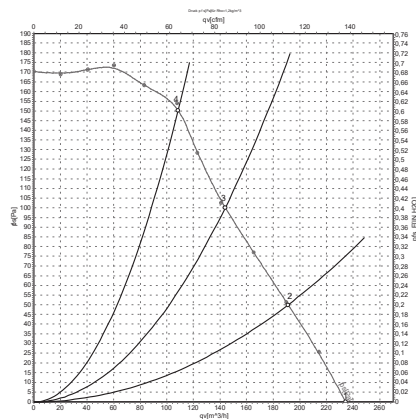
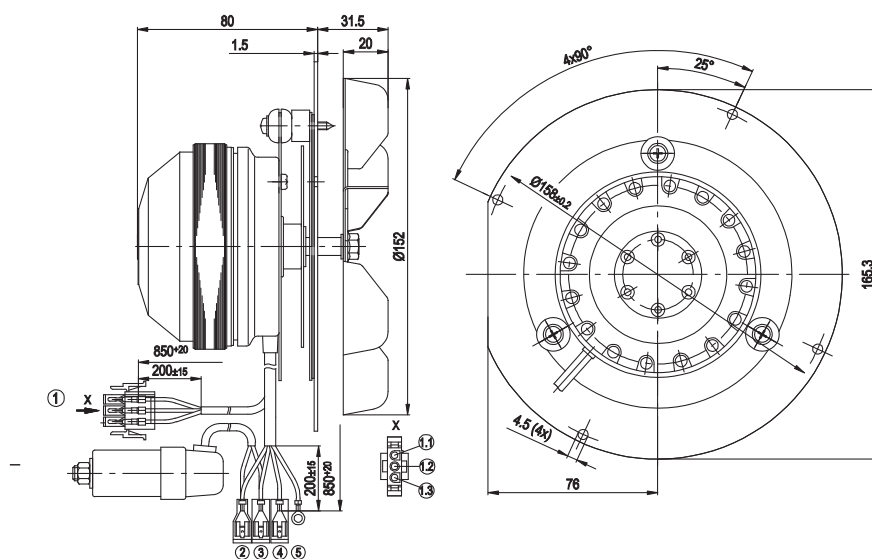

	V	Hz	rpm	W	A	m ³ /h	Pa
1	230	50	2400	32	0.14	235	0
2	230	50	2375	32	0.14	190	50
3	230	50	2400	31	0.13	145	100
4	230	50	2590	29	0.13	110	150

Fan diagram

- U1 Blue
- Z Brown
- U2 Black
- PE Yellow/Green
- 2 Plant circuit
- 2.1 Plant circuit
- 2.2 Red (+5V)
- 2.3 White (out)
- 2.4 Black (0V)

PHASES	V/Hz	rpm	W	A	μF	TEMP. AMBIENT max °C	STARTING current a	kg	BLADE n°	INSUL. class	CODE
1~	230/50	2400	32	0,14	1	80	0,2	1,7	6	B	0411906

By request an even wider range for pellet stoves